

meg-7.5 / Sirius 750

and

meg-4.5 / Sirius 450

SOLID FUEL HEATING STOVES

Registered at the UK Patent Office: No 4014952, 4014953

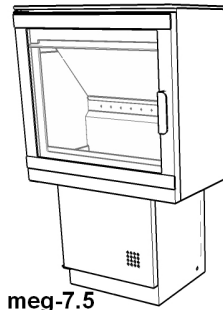

meg-7.5
Sirius 750

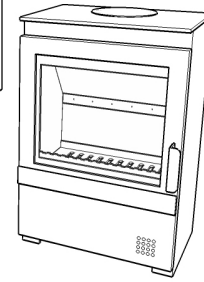

meg-4.5
Sirius 450

Meg Solid Fuel Stoves
Manual issued -
23/11/2011 (119)

INSTALLATION AND OPERATING INSTRUCTIONS

LEAVE THIS DOCUMENT WITH THE HOUSEHOLDER!



All Meg Stoves exceed the safety and performance requirements of European Standards
Independently tested by SGS (Notified Laboratory No:0608) in 2010.
Intermittent burning solid fuel roomheaters for installation with a single dedicated chimney.

	meg-7.5 / Meg M / Sirius 750		meg-4.5 / Sirius 450		meg-4.5 / Sirius 450 Inset version	
Fuel	Wood (Beech)	Mineral Fuel (Anthracite)	Wood (Beech)	Mineral Fuel (Anthracite)	Wood (Beech)	Mineral Fuel (Anthracite)
Test Standard	EN 13240:2001+A2 2004				EN13229	
Test Cycle	1.76kg over 0.82hrs	1.56kg over 1.01hrs	1.36 over 0.83hrs	0.9kg over 1hr	1.36 over 0.83hrs	0.9kg over 1hr
Settings	Primary 0, 2nd 100%	Primary 75%, 2nd 0%	Primary 0%, 2nd 0%	Primary 50%, 2nd 0%	Primary 0%, 2nd 0%	Primary 50%, 2nd 0%
Flue Draught Pa (ins WG)	12 (0.05)	12 (0.05)	12 (0.05)	12 (0.05)	12 (0.05)	12 (0.05)
Efficiency %	78.5	80.1	81.0	81.2	81.0	81.2
Recommended Rating kW	7.5		4.5kW		4.5kW	
Mean Flue Gas Temp Rise °K	253	248	248	294	248	294
Minimum air entry requirement	4000 mm ² , or via optional direct air supply tube.		2500 mm ²		2500 mm ²	
Minimum Clearance to combustibles	at back, 500mm, at sides 400mm		Back and sides, 400mm		150mm at sides, 400mm above, when fitted in masonry fireplace.	
Hearth	A light duty hearth may be used		A light duty hearth may be used		A standard hearth should be used	
Weight	95kg		60kg		58kg	
Flue outlet size	150mm		125mm		125mm	
Emissions as if O ₂ =13%	NOx mg/m ³	115	-	105	-	105
	CO %	0.07	0.09	0.02	0.03	0.02
	CxHy mg/m ³	29	-	232	-	232
	Gas flow g/sec	6.1	6	4.1	3.7	4.1
	Smoke Emission g/hr	1.0	-	1.98	-	1.98

Read these instructions! Use only recommended fuels!



This document, when completed by the installer, constitutes part of a 'Hearth Notice' for purposes of Building Law. It must be left with the householder and placed where it can easily be found.
INSTALLED AT LOCATION:

BY:

I definitively assert that this installation is safe, has been lit and demonstrated to the householder, conforms with current building regulations and with these instructions

SIGNED:

DATE:

Flue Draught measured on commissioning:

Pa
WG

Fuel used on commissioning

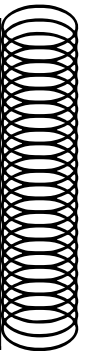

TO FIND A QUALIFIED INSTALLER, FUEL SUPPLIER or CHIMNEY SWEEP, CONTACT:

UK: The Solid Fuel Association, 7 Swanwick Court, Alfreton, Derbyshire DE55 7AS Tel:0845-601-4406 www.solidfuel.co.uk

RoI: Irish Nationwide Fireplace Organisation, 162 Capel Street, Dublin 1 Tel:01-801-5959 www.fireplace.ie

Manufactured by: **Meg Stoves, Station Works**

Hooton Road, Hooton, South Wirral CH66 7NF www.megfire.com

The meg-7.5 / Sirius 750 and meg-4.5 / Sirius 450 stoves may be used in smoke control areas strictly in accordance with these instructions, when burning:

UK: Untreated wood logs, natural anthracite or authorised smokeless fuels (authorised under s20(6) of the **Clean Air Act 1993**)

RoI: Wood logs, smokeless fuels or peat briquettes, but *not* petroleum coke (**Control of Atmospheric Pollution Regulations, 1970**)

THIS APPLIANCE BECOMES EXTREMELY HOT AND CAN PRODUCE POISONOUS GASES.

A fire-guard should be used if children or the infirm are present. The installer is required to **EXACTLY** follow these instructions and to completely comply with all local, national and international standards.

Building regulations are available at www.soliftec.com

INSTALLING a stove is a 'controlled service', the law expects that it is either supervised by a qualified installer or that the building inspector is informed. Check with your local authority.

ASBESTOS: Your stove does not contain asbestos, but take care to avoid disturbing asbestos in an old installation.

WEIGHT: Your stove is heavy - take great care when moving it and ensure that the intended fireplace can support the weight- consider fitting a load distributing plate.

YOUR CHIMNEY, by becoming warm, makes the gas inside it rise, pulling fresh air into the stove to make it work. It must::

- Generate a draught in use of at least 12Pa (0.05ins wg)
- Be capable of withstanding the temperatures generated.
- Be absolutely incapable of leaking fumes into the dwelling This will commonly be achieved by it:
 - Being at least 5m high.
 - Terminating at least 1m above any roof ridge.
 - Having an internal cross-section not less than 0.018m² (eg 150mm dia) and never more than 0.14m² (eg 375 x 375mm)
 - Being free from even the slightest crack or source of leakage.
 - Having no bends sharper than 45°.
 - Being entirely free of obstructions and swept by a qualified chimney sweep.
 - Being connected only to this one appliance.
 - Being of thick masonry or otherwise adequately insulated.
 - Conforming to local building regulations.

Special rules apply where the flue passes through timber, thatch or other vulnerable materials- take specialist advice.

Although it is possible to access the chimney through the fire with the throat plate removed, fit hatches to provide cleaning access if needed.

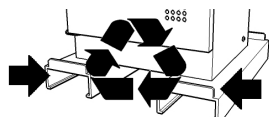

Please return the transit skids – they will be re-used!

YOUR FIREPLACE: Stoves become VERY hot, the setting must be made entirely of durable fireproof materials. Thin (<50mm) stone slabs risk cracking unless cut into sections to allow for expansion and backed with a heat resistant concrete. Even beyond the safety clearance, items can still become very hot - take great care in siting vulnerable materials like wax, textiles, paper etc.

AIR SUPPLY: Your stove needs air to breathe - there must be a permanent fresh air supply into the space in which it is installed equal to the size given on page 1. This can often be provided by air leaking around door frames etc. (it is commonly accepted that this alone may suffice for appliances <c5kW) but in any case of doubt, fit a purpose-made air vent. An extractor fan, or another fuel-using appliance in the same building, can remove this air.

The direct outside air supply kit for the MEG7.5 stoves does away with the need for a vent into the room space - refer to the instructions supplied with the kit.

Fit a Carbon Monoxide alarm near to the stove.

FITTING

Fasten the flue outlet and blanking plate to the top or back flue outlet opening, on a thin bed of fire cement. Do not over tighten.

Place the stove on a solid non-combustible hearth conforming to building regulations, noting the distances to combustible materials given in the table on the front of this document.

Prepare to fix the stove in place by drilling two 6mm diameter holes at suitable fixing centres, 50mm deep into the hearth. Insert the washers and bolts supplied and partly screw down. Slide the stove under the washers and tighten using a spanner.

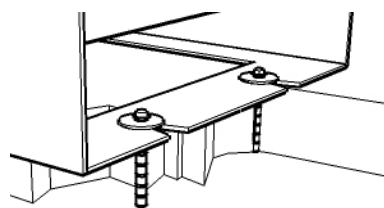

Fixing down - rear view

Your stove can be sealed to the chimney using a **short** (up to about 500mm) length of uninsulated pipe in several ways, four of which are shown.

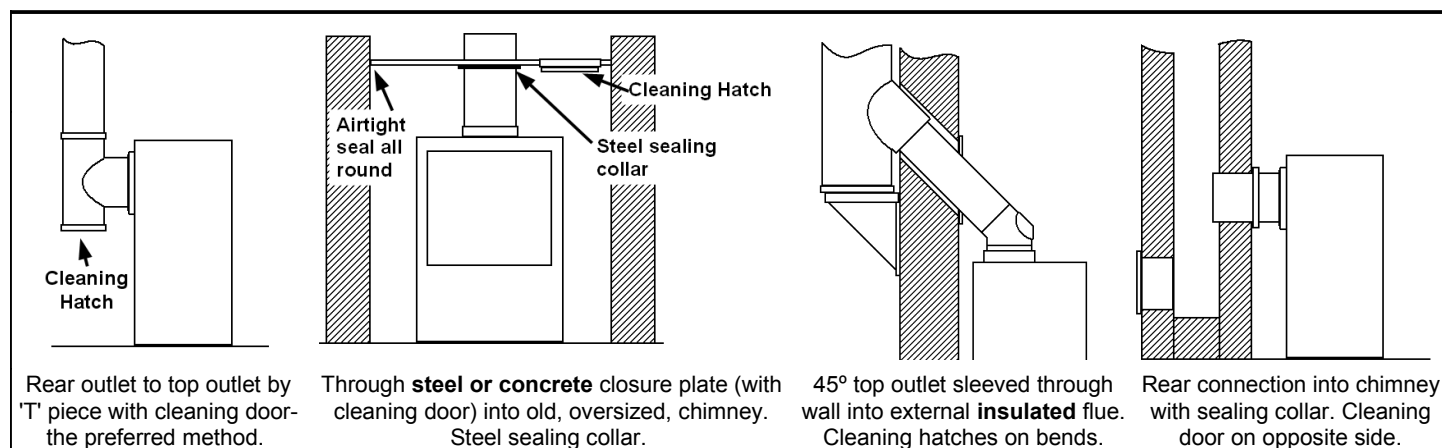

Whichever method is used it is imperative that: (1) The route for gases from the stove to the chimney terminal is completely air-tight; even the tiniest gap of crack can spoil the updraught. Seal all joints with fireproof cement and/or heatproof rope. (2) It is possible to sweep the entire length- access doors may be required. (3) The entire construction is of durable fireproof materials.

CHECK THE INSTALLATION !

Once installed, light the fire, demonstrate it to the householder and check that:

- 1) It burns controllably and does not emit fumes to the room
- 2) The route for gases from the stove to the chimney terminal is **completely** airtight, unobstructed and able to be swept.
- 3) The entire construction is of durable fireproof materials.
- 4) The flue presents a draught in use of at least 12Pa

LIVING WITH YOUR STOVE

Every fuel, chimney and condition of use is different. Only experience will show which are the best settings for you.

LIGHTING If lighting after a period of non-use, do check that the flueways and chimney are completely clear. Place two or three firelighters close together, or screwed-up paper covered with dry sticks, at the back of the grate and light them. When they are burning well gently cover them with VERY dry fuel, close the door and set the air controls to the 'high' position (see 'CONTROL'). When the fire is burning well, move the controls to the lowest practical setting.

FILLING: Meg are very efficient stoves, you don't have to pile them up with huge amounts of fuel. Just one or two logs of about 1kg each, or mineral fuel mounded up in the centre is all that is needed. Don't fill above the level shown in the diagram. Once a bed of cinders has built up, just adding a single log each hour or so is usually all that is needed.

CONTROL How fast the fire burns depends on how much air reaches the fuel. The stove has two air controls, one below the

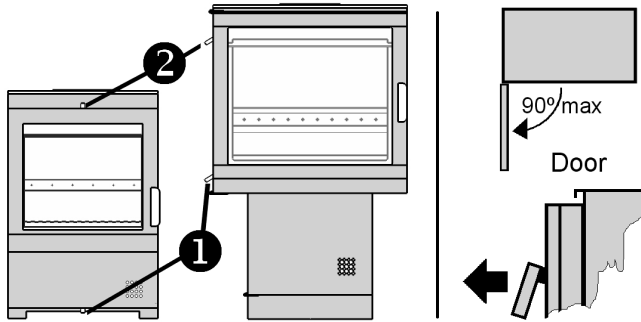

window ('primary' ①) and one above ('airwash control' ②). Move the slides up or right for 'high' or down or left for 'low'. They can get very hot, so move them only with the tool or glove supplied.

To open the door, fully lift the door handle and pull. To close the door, fully lift the handle, push the door closed and then push the handle forward to lock. Open the door (never past 90°!) only for refuelling and de-ashing. Keep it tightly closed in use.

When using **wood**, always make sure that the primary control ① is completely closed, and adjust the burning rate using the airwash ② control. Hard fuels like anthracite work best with the airwash closed and the primary open.

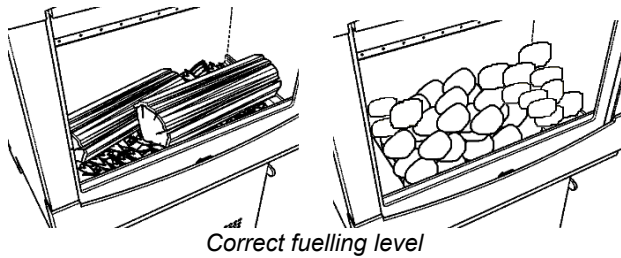

EMPTYING ASHES only when the fire is cold. Use the tool or a glove to open the door. Stir the fire with a poker before lifting out the ashbin. Remember to let ash cool before disposing in plastic sacks or dustbins. There is no need to empty every last speck, but ash from mineral fuels should never be allowed to build up so that it comes into contact with the underside of the grate.

EXTENDED BURNING Meg stoves are intended for quick heat-up intermittent use. While well capable of lasting for many hours, they are not designed for overnight burning. Allow the fire to burn down to a low, hot firebed, and fully fill with hard fuel such as anthracite (c30mm size is best). Set the air controls to 'low'.

KEEPING THE WINDOW CLEAN Simply operating the stove for a few minutes at high output will often burn-off any deposits left by tarry or wet fuels. Severe stains can be removed when cold with a domestic bleach cleaner. The window is not glass but a transparent ceramic, it may develop tiny hairline cracks, these are harmless, and a characteristic of the toughest heat-resistant material known. Reduce the risk of staining by using only very dry fuel and keeping the airwash ② control at least a little open.

OPENING THE DOOR This stove is designed to be operated only with the door closed. The door handle can get very hot so use the tool or glove provided. Open the door very slowly to minimise fume emission and prevent hot fuel falling out.

SUMMER SHUT DOWN: Before a long period of non-use, empty fuel and ash, remove the throat plate and leave all the air controls open to allow ventilation to reduce condensation.

FUELS

There is no 'perfect' fuel, so we strongly recommend that you try a selection of fuels (or mixtures) to find which suits you best. Do avoid dusty materials like sawdust, they can burn far too violently.

SMOKE CONTROL: In certain areas special rules apply to reduce smoke nuisance. Check with your local authority.

WOOD only emits as much carbon to the atmosphere as the tree took in when growing, so wood is considered the 'carbon neutral' fuel. When wood is cut down its cells are full of water. Burning such wet or 'green' wood wastes heat in making steam and produces flammable, acidic tars which will cling to, and rapidly damage, your stove and chimney. Split logs will typically take two years to become reasonably dry, round logs much longer. Cracks in the ends, a hollow sound when tapped and bark falling away are all signs that a log may be ready for use. The fine, white residue produced when wood burns is not ash, but the remains of cell walls which can burn if kept hot enough, so don't de-ash a fire until absolutely necessary when using wood.

Meg appliances are authorised for use in smoke control areas of the UK when burning dry wood logs.

For best performance, and always for low smoke emission:

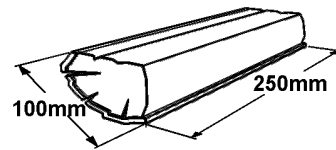

- Minimise smoke emission from wood by:
- Split logs lengthways for drying
- Use logs no bigger than about 100mm x 250mm
- Ensure logs are absolutely dry (less than 15% moisture)
- Fill the stove criss-cross, so air can circulate between logs.
- Fill 'little and often'
- Always have the airwash control (2) at least a little open.
- When first lighting, or reviving a fire from embers, use only very small, thin, dry, sticks.
- Never operate with the door open.
- Don't overfill the firebox – see the diagram above.

JOINERY WASTE Dry wood offcuts will burn well, but don't expect softwood waste to burn as cleanly or for as long as hardwood logs.

PEAT (Not Smokeless in UK. Smokeless in the RoI.) Sod turf must be thoroughly dry.

LIGNITE (Not smokeless) is a natural mineral, between peat and coal. It lights easily and burns well, but produces much ash

HOUSECOAL or **BITUMINOUS COAL** (Not smokeless) makes lots of tarry smoke and large volumes of flammable gas which make it difficult to control and risk explosions. Despite its low cost, it rarely represents value for money. Never use housecoal.

ANTHRACITE (Smokeless) is a natural hard, shiny form of coal. Slow to light, it can burn for very long periods with great heat. Despite its high price-per-bag it generally works out to be one of the cheapest of all fuels. Use the 'small nuts' size.

COKE (Smokeless) is coal from which the smoke has been removed. Sometimes difficult to light, it burns very cleanly.

BRIQUETTES Are compressed blocks of fuel, generally able to burn for long periods and remarkable for their consistency. 'Homefire' and 'Phurnacite' are smokeless types while other brands are made from lignite, peat or housecoal.

PETROLEUM COKE (Smokeless in the UK, forbidden in smokeless zones in the RoI) sold as 'Petcoke', 'Longbeach' and under various proprietary names, is made from oil. Easy to light and to control, its exceptional heat and lack of protective ash mean that it MUST NOT be used unless mixed with another fuel. Grate and liner life will be drastically reduced when using petroleum coke

HOUSEHOLD WASTES Some plastics give off toxic fumes when burned and remember that batteries and aerosols explode! The stove is not an incinerator, so only ever use the recommended fuels and NEVER use liquid fuels in any form.

PROBLEMS?

Problems like those listed here are usually due to some difficulty

with the installation, chimney or fuels, so please check back through this leaflet carefully. If necessary seek specialist advice.

SMOKE FROM THE CHIMNEY It is quite normal for a little smoke to be emitted from the chimney when the fire is cold, so, start the fire using only a very little fuel. When using **wood**, always make sure that the primary control ① is *completely* closed. and adjust the burning rate using the airwash ② control. Use only **VERY** dry wood or smokeless fuels.

POOR HEAT OUTPUT: A stove can heat a typical room of *about* 12m³ volume for each kW of output, so a 5kW model can heat up to (12 x 5) 63m³, a room of about 5m square. The actual size depends on the insulation and air-change ratio of the room. To attempt to heat a larger room will result in excessive fuel consumption and damaging overheating.

LACK OF CONTROLLABILITY Wood and some other fuels may burn excessively until the gases in them have been used up. You can reduce this effect by making sure that the fire is set to 'low' for a while before refuelling and checking that the door seals fully.

CONDENSATION onto cool surfaces inside the stove can be severe if fuel is in any way damp. *Use only very dry fuel.*

OVER-FIRING: It is possible to leave the fire too long with the controls set too high leading to 'over firing', seen as glowing metal parts, excessive chimney temperature and risk of parts failing or chimney fires. Always set controls to the lowest practical setting. A chimney thermometer, from your local stove shop, can help.

SMOKE COMING INTO ROOM Fumes are poisonous- smoke emission must NEVER be tolerated, causes might be:

NEW STOVE: There is often a smell and sometimes visible fumes as the paint cures. This normally stops after an hour or so.

INADEQUATE SEALS: Are all flue pipes and connectors *absolutely* gas-tight? Even the tiniest crack or gap can spoil the draught. Does an inset appliances fully seal against the fireplace?

BLOCKED THROAT PLATE: Has soot and ash collected on the 'throat plate' above the inner back part of the firebox?

UNSUITABLE, BLOCKED OR UN-SWEPT CHIMNEY: The first requirement for correct operation is a sound chimney. Check the requirements earlier in this document and in any case of doubt engage a professional sweep or chimney engineer.

POOR AIR SUPPLY: Lack of air to the fire is a common cause of smoking and poor performance. Air supply problems may be worse in certain wind conditions (often incorrectly ascribed to 'downdraught', which is in fact very rare), where air can be sucked out of the room. The answer is to fit an air vent, as near to the fire as possible, facing into the usual wind direction.

DOWNDRAUGHT: Wind can blow *down* a chimney if there is

something higher nearby such as a tree, hill or high building. Fitting an anti-downdraught cowl to the chimney top can cure this. Types which cannot be swept through are not recommended.

POOR CHIMNEY DRAUGHT- Chimney draught in use **MUST** be at least 12Pa.

CHIMNEY FIRE: In the rare event of deposits inside the chimney igniting (roaring sound + dense smoke and sparks from the chimney) immediately close the door, shut all air controls and call the fire brigade. Prevent fires by using *very dry fuel* and having your chimney swept regularly.

MAINTENANCE

MONTHLY- Check that the flue is clear and unblocked, and that

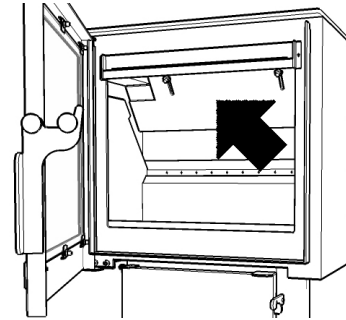

Access to flueways for inspection

the door seals are sound.

ANNUALLY- SWEEP THE CHIMNEY The entire length of the chimney from stove to outlet should be swept annually, more often if smoky fuels are used.

NEW PARTS Your stove has been extensively tested for safety - please don't try to modify it and always obtain genuine spare parts.

SURFACE FINISH Wipe the stove body with a slightly damp cloth when cool. NEVER use aerosol spray or wax near the hot fire - they can ignite. Painted steel parts can be refurbished using special spray stove paint.

Your stove generates **VERY** high temperatures. Eventually the internal parts will require replacement. Help parts to last by:

- Using only recommend, *very dry*, fuels.
- Emptying the ash very regularly when using mineral fuel -never allow it to touch the underside of the grate.
- Cleaning the internal flueways regularly.
- Avoiding 'over-firing'

PARTS AND ACCESSORIES

Replaceable parts, shown below, are identified by name and by the model number; MEG 7.5 Sirius 750 / or MEG 4.5 / Sirius450 (7.5 versions shown.) The numbers show the order of removal, they are refitted in the reverse order. (The larger 7.5 model shown, parts in the 4.5 fit in the same way, but are slightly different in appearance).

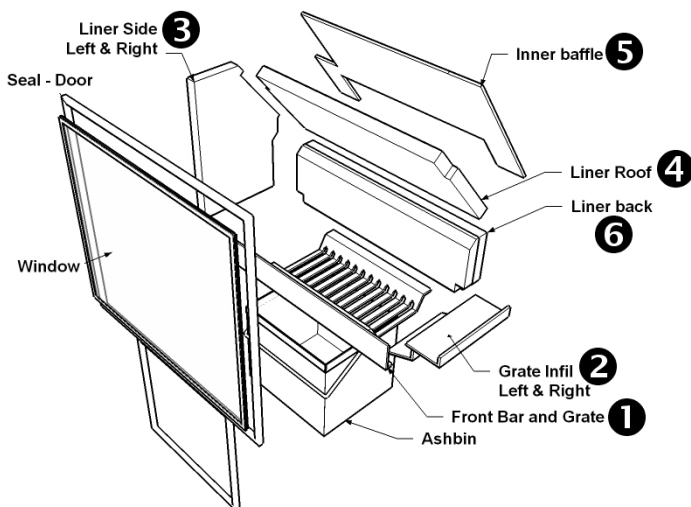

Designed, developed and built in England
Meg Stoves, Station Works
Hooton Road, Hooton, South Wirral CH66 7NF
www.megfire.com